

General Arrangement Drawing

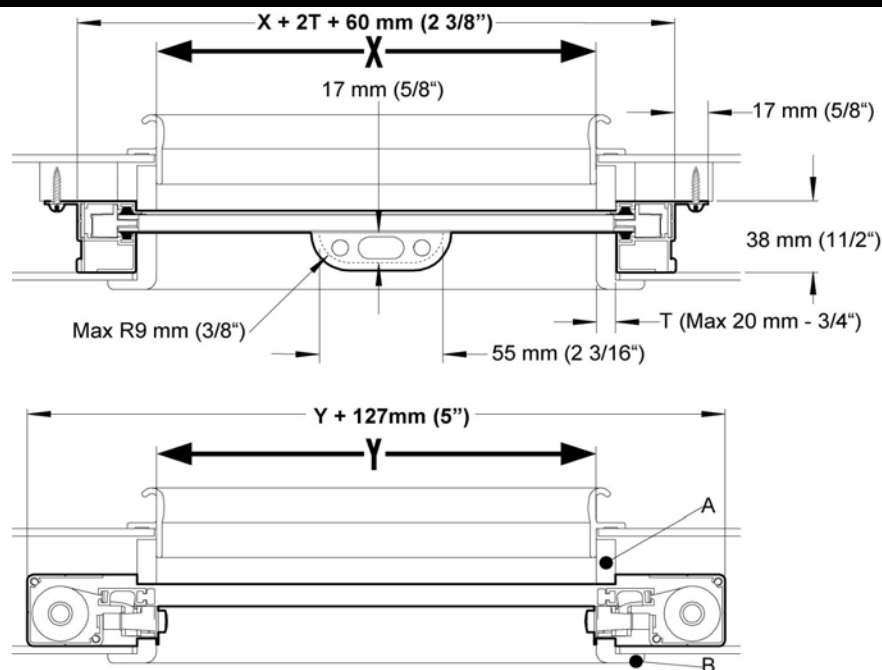

Install Design Points

- The Concealed SKYscreen2 has no visible design impact on the yachts interior
- Handle recess cut out of trim – template supplied
- The blind and flyscreen emerge from a 10mm ($\frac{3}{8}$ ”) slot in the hatch liner
- Flyscreen brushstrip top and bottom of the track
- The side rails are designed to support the headlining panel and hatch trims

Custom

- Overall size - width $X + 2T + 94\text{mm}$ ($3\frac{3}{4}$ ”), drop $Y + 127\text{mm}$ (5”), height 47.5mm ($1\frac{7}{8}$ ”)
- If the ‘Y’ measurement exceeds the ‘X’ measurement by more than 30%, please contact Oceanair before ordering
- Blind size : minimum X & Y is $200/200\text{mm}$ ($7\frac{7}{8}$ ” by $7\frac{7}{8}$ ”), maximum X & Y is $800/800\text{mm}$ ($31\frac{1}{2}$ ” by $31\frac{1}{2}$ ”). For larger sizes contact Oceanair
- Other fabrics on application

How to Order

- Standard size : Lewmar Ocean range with liner not exceeding 20mm ($\frac{3}{4}$ ”)
- Use custom order form for all sizes

Technical Specification

- Aluminium is anodised to 25 microns joined by stainless steel corner brackets
- Nylon brush strip
- Button housing available in chrome, dark grey and white. The button is always light grey
- Magnetic strip – corrosion free and maximum 75mm (3”) magnetic field
- Standard fabric: Solar Shield off-white polyester blackout water repellent fabric
- Flyscreen – glass fibre mesh PVC coated flyscreen in white