

# DOMETIC SKYVENETIAN

LEATHER

Powered - 50mm Slat - Side Tracks - 24V DC Sonesse 30 DCT/RTS

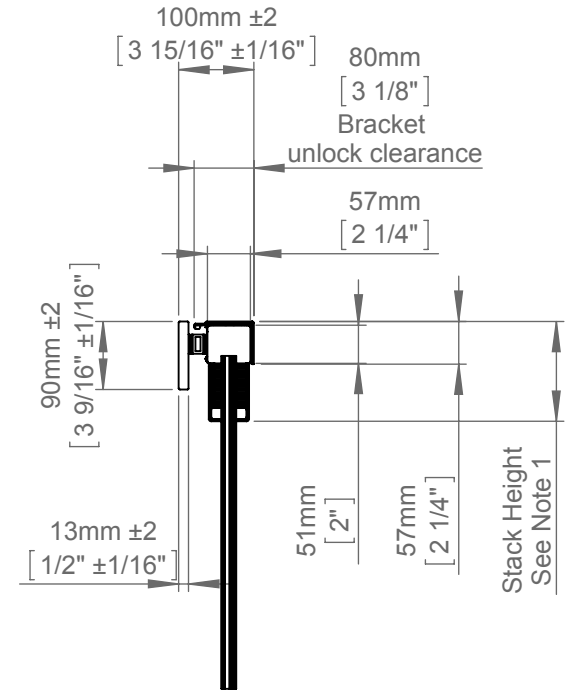
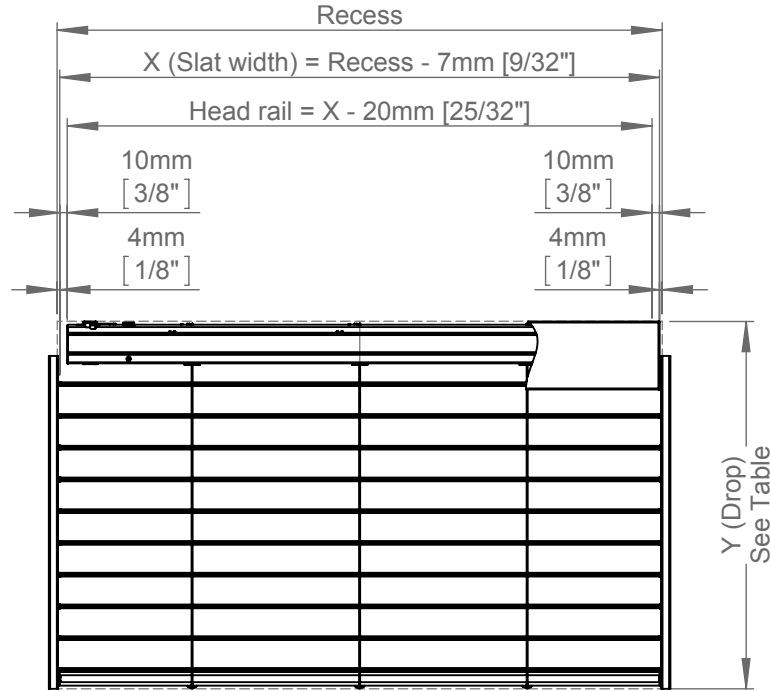
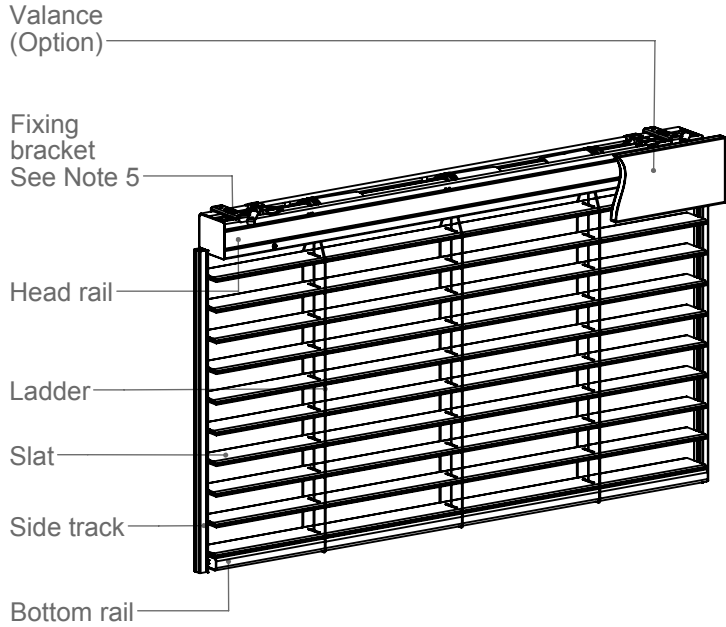

- Notes:
- 1 Refer to Oceanair for further stack height information.
  - 2 Refer to Oceanair for minimum and maximum drop information.
  - 3 X (Max leather) = 1800mm [70 7/8\"], X (Min faux leather) = 2400mm [94 1/2\"].
  - 4 Motor exit wire can exit either side, please specify.
  - 5 Bracket quantity dependent on width of blind.
  - 6 Dimensions in millimeters (Imperial equivalents are shown for reference only).

| X(Width) & Y(Drop) Limits |            |            |
|---------------------------|------------|------------|
| X (Min)                   | X (Max)    | Y          |
| 680mm [26 25/32\"]        | See Note 3 | See Note 2 |

