

VIEW FROM INBOARD

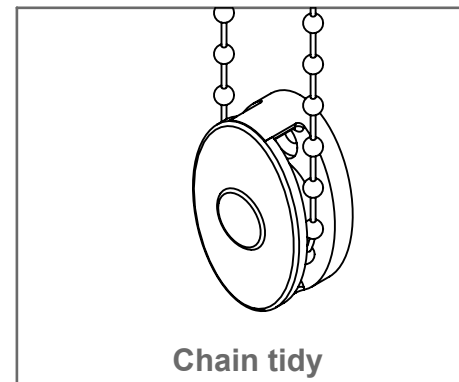
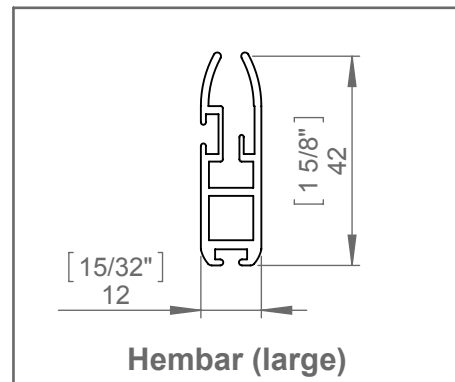
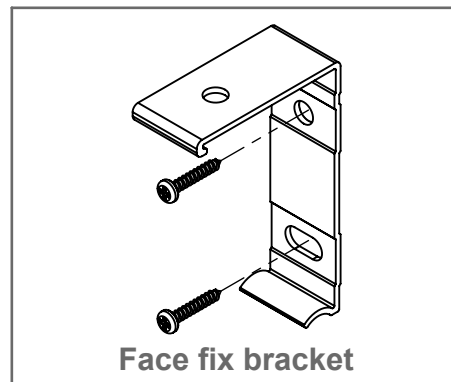
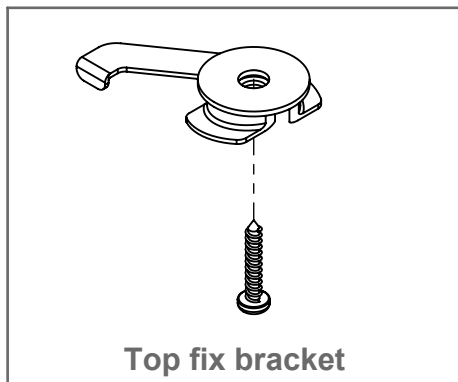

X(Width) & Y(Drop) Limits		
X(Min)	X(Max)	Y
350 $\left[ \frac{13}{25} \right]$	2400 $\left[ \frac{94}{2} \right]$	See Note 2

- Notes:
- Overall head rail size (X) = Recess - 4  $\left[ \frac{5}{32} \right]$ .
  - Maximum drop (Y) fabric dependant, consult Oceanair.
  - Hembar (small) shown, hembar (large) available depending on blind size and fabric, consult Oceanair.
  - Bracket quantity dependent on width of blind.
  - Allow sufficient space for installation.
  - Dimensions in millimeters (Imperial equivalents are shown for reference only).