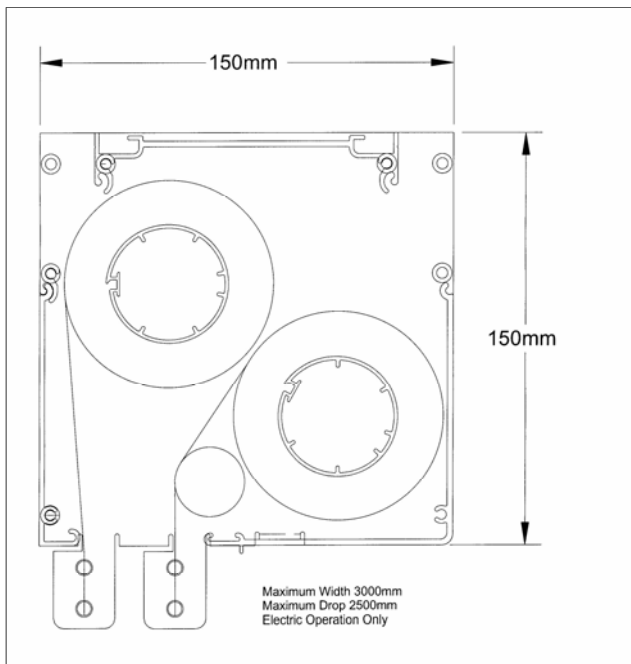
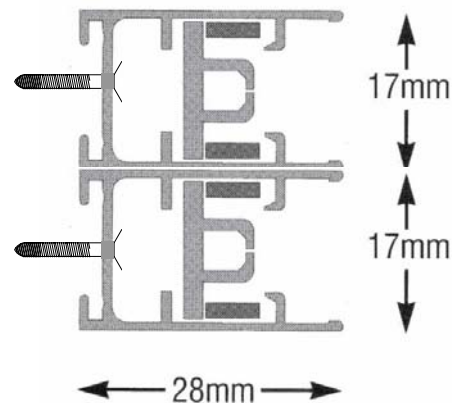

General Arrangement Drawing**Side Guide****Features**

- Total light control within one system – two cloths, one blackout, one shading
- Neat, efficient and robust top cassette containing cloth, roller and all necessary operating mechanism
- Cloth zips into the inner channel and is held secure along its entire length
- Thin two part side guide section, comprising an aluminium outer channel and a uPVC inner channel
- Thin bottom channel guide for the cloth to link into and seal against when blind is drawn
- Manually operated endless loop side chain.
- The innovative cloth guide system allows for narrow and extra long blinds.
- Powered versions available: simple control switch; remote control; or automatic system. A 240v AC electric motor with built-in limit switches is fitted within the head box to give a simple and trouble free use.
- Twin roller box available in 150mm

Install design points

- Access for maintenance is via a removable front cover

How to Order

- To order – contact Oceanair

Technical Specification

- Head box, side and bottom channel are powder coated aluminium available in white (RAL 9010) or black as standard.
- Side chain mechanism includes non-slip clutch system.
- Side chain available in white, grey, beige and bright steel

Dometic UK Blind Systems Ltd Chichester PO20 0AY England

Tel +44 (0)1243 606909 Fax +44 (0)1243 608300 www.dometic.com E-mail blindsystems@dometic.com